

PACSafe™ Controller with Relay Outputs IPI

IC225SSE102

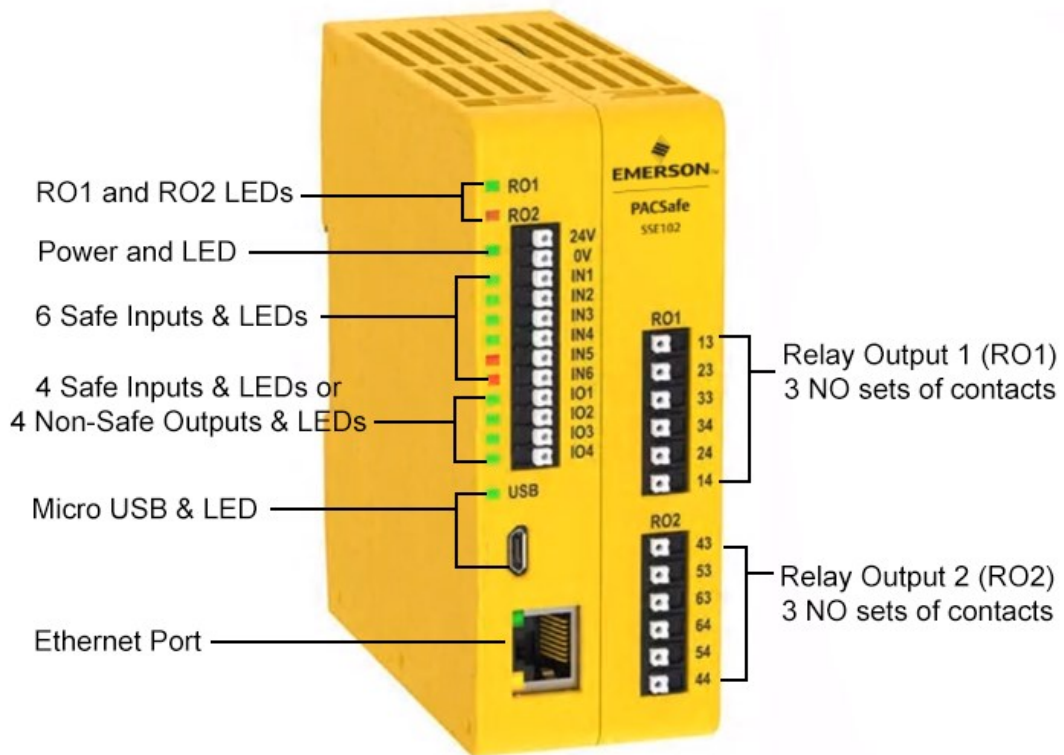

⚠ WARNING

Warning notices are used in this publication to emphasize that hazardous voltages, currents, temperatures, or other conditions that could cause personal injury exist in this equipment or may be associated with its use.

In situations where inattention could cause either personal injury or damage to equipment, a Warning notice is used.

⚠ CAUTION

Caution notices are used where equipment might be damaged if care is not taken.

Note: Notes merely call attention to information that is especially significant to understanding and operating the equipment.

These instructions do not purport to cover all details or variations in equipment, nor to provide for every possible contingency to be met during installation, operation, and maintenance. The information is supplied for informational purposes only, and Emerson makes no warranty as to the accuracy of the information included herein. Changes, modifications, and/or improvements to equipment and specifications are made periodically and these changes may or may not be reflected herein. It is understood that Emerson may make changes, modifications, or improvements to the equipment referenced herein or to the document itself at any time. This document is intended for trained personnel familiar with the Emerson products referenced herein.

Emerson may have patents or pending patent applications covering subject matter in this document. The furnishing of this document does not provide any license whatsoever to any of these patents.

Emerson provides the following document and the information included therein as-is and without warranty of any kind, expressed or implied, including but not limited to any implied statutory warranty of merchantability or fitness for particular purpose.

Models

For complete technical information about this product, including installation instructions, application requirements and guidelines, technical specifications, and accessories, go to the support site links at the end of this document and search for the PACSafe Configurable Safety Controller User Manual (GFK-3184).

Model	Description
IC225SSE102	Configurable Safety Controller; Standalone; ISD Compatible; 10 Inputs 2 Relay Outputs (3 NO, 6 amp each); Ethernet; Terminal LEDs; 4 Convertible Inputs; Push-in Spring Clamp Terminals; 24 V dc; 240 to 580 mA

Features

- Intuitive, icon-based programming with drag-and-drop PC configuration simplifies device setup and management
- Supports a wide range of safety devices, eliminating the need to buy and stock safety relay modules dedicated to specific safety devices
- Two six-amp safety relay outputs, each with three N.O. sets of contacts
- Ten inputs, including four that can be used as non-safe outputs
- Automatic Terminal Optimization (ATO) can increase the inputs from 10 to up to 14
- Industrial Ethernet two-way communication
 - 256 virtual non-safe status outputs
 - 80 virtual non-safe inputs (reset, on/off, cancel off-delay, mute enable)
- Optional IC225ACC001 external drive for fast swap and quick configuration without a PC

Note: Configuration software is required. The software is available at the support links listed at the end of this document.

Configuration Diagram (SSE102)

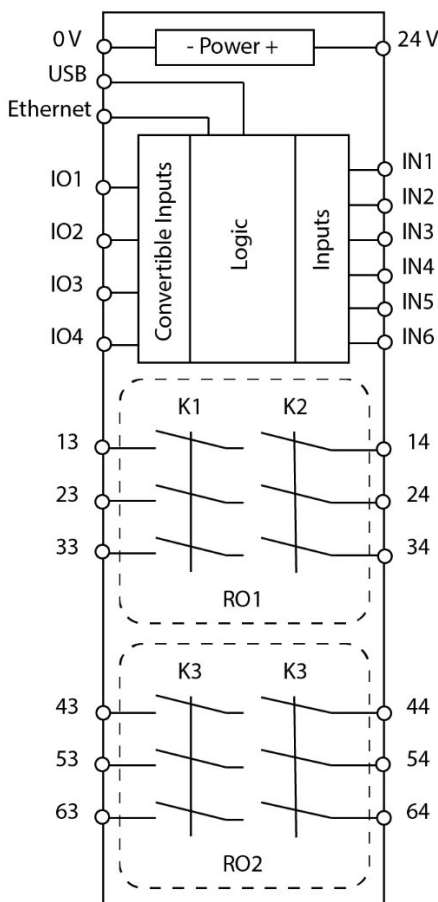

Related Information

Description of Manual	GFK Number
PACSafe Configurable Safety Controller Quick Start Guide (QSG)	GFK-3183
PACSafe Configurable Safety Controller User Manual	GFK-3184
PACSafe Secure Deployment Guide (SDG)	GFK-3188
PACSafe Interface Module User Manual	GFK-3195
PACSystems RX3i and RSTi-EP Profinet I/O Controller User Manual	GFK-2571
PACSystems RX3i System Manual	GFK-2314

In addition to these manuals, product update documents describe individual product revisions. The most recent PACSystems documentation is available on the Support website: <https://www.emerson.com/Industrial-Automation-Controls/support>.

Important Product Information for this Release

Initial Release

Release History

Firmware Version	Date	Description
1.0	Oct 2020	Initial Release

Functional Compatibility

Subject	Description
GSDML Version	IC225SSE102: GSDML-V2.33-IntelligentPlatformsLLC-IC225SSE102-20200925.xml IC225SXF262/SXE262/SXD262/SXO262: GSDML-V2.32-IntelligentPlatformsLLC-IC225Sxx262-20200925.xml
PAC Machine Edition™ Logic Developer PLC Programmer Version Requirements	PAC Machine Edition Logic Developer PLC 9.80 SIM 5.
Firmware Version	IC695CPE100/CPE115/CPE302/CPE305/CPE310/CPE330/CPE400/CPL410 Firmware Release 10.05 VersaMax Micro PLUS PLC Firmware Release 4.03

Restrictions and Open Issues for Release 1.0

Subject	Description
No Defects	No Known Defects or Open Issues with this Release

Operational Notes

None

Responsibilities of Qualified Personnel

To access the Configurable Safety Controller instruction manual (GFK-3184):

Go to Emerson's support site to download the manual

WARNING

It is the responsibility of the Qualified Personnel to:

- Carefully read, understand, and follow the information in the Configurable Safety Controller (GFK-3184) instruction manual
- Perform a risk assessment of the specific machine guarding application
- Determine what risk reduction measures are appropriate per the results of the risk assessment
- Properly install, configure, and then verify that the risk reduction measures are working as intended
- Periodically re-verify, as needed, that the risk reduction measures are working as intended.

Failure to follow any of these responsibilities may potentially create a dangerous condition that could lead to serious injury or death.

Pour accéder au manuel d'utilisation Configurable Safety Controller (GFK-3184).

Rendez-vous sur le site <https://www.emerson.com/industrial-automation-controls/support> pour télécharger le manuel dans la langue de votre choix

WARNING

Il incombe au personnel qualifié de:

- Lire avec attention, bien comprendre et suivre les instructions du manuel du système Configurable Safety Controller (GFK-3184)
- Effectuer une évaluation des risques de l'application de protection spécifique à la machine
- Identifier les mesures de limitation du risque appropriées en fonction des résultats de l'étude de risques
- Installer et configurer correctement le ou les dispositifs de protection destinés à limiter le risque puis vérifier qu'ils fonctionnent de la façon prévue
- Révérer périodiquement, s'il y a lieu, que ces dispositifs de protection fonctionnent toujours comme il se doit

Le non-respect de l'une de ces responsabilités peut potentiellement créer une condition dangereuse pouvant entraîner des blessures graves, voire mortelles.

So beziehen Sie die Bedienungsanleitung für den Configurable Safety Controller (GFK-3184):

Laden Sie die Anleitung in der gewünschten Sprache von unserer Website (<https://www.emerson.com/industrial-automation-controls/support>) herunter oder

WARNING

Es liegt in der Verantwortung des qualifizierten Personals,

- Die Informationen in der Anleitung für den Configurable Safety Controller (GFK-3184) gründlich durchzulesen, zu verstehen und zu befolgen
- Eine Risikobeurteilung der spezifischen Maschinenschutzanwendung durchzuführen
- Ermitteln, welche Maßnahmen zur Risikominderung aufgrund der Ergebnisse der Risikobeurteilung angemessen sind
- Das gesamte Schutzsystem fachgerecht installieren, konfigurieren und anschließend auf die bestimmungsgemäße - Funktion überprüfen
- Je nach Bedarf regelmäßig nachprüfen, ob die Maßnahmen zur Risikominderung wie beabsichtigt funktionieren

Die Nichtbeachtung einer dieser Verantwortlichkeiten kann zu gefährlichen Zuständen führen, die zu schweren oder tödlichen Verletzungen führen können.

Per accedere al manuale di istruzioni dello Configurable Safety Controller (GFK-3184):

Andare al sito <https://www.emerson.com/industrial-automation-controls/support> per scaricare il manuale

WARNING

È responsabilità della Personale Qualificato:

- Leggere attentamente, assicurarsi di avere compreso e seguire le indicazioni riportate nel manuale di istruzioni del Configurable Safety Controller (GFK-3184).
- Eseguire una valutazione dei rischi dell'applicazione di protezione della macchina specifica
- Determinare quali misure di riduzione del rischio sono appropriate in base ai risultati della valutazione del rischio
- Installare e configurare correttamente il sistema, quindi verificare che le misure di riduzione del rischio assicurino i risultati previsti
- Ricontrollare periodicamente, in base alla necessità, che tali misure di riduzione del rischi continuino ad assicurare i risultati previsti.

La mancata osservanza di una qualsiasi di queste responsabilità può potenzialmente creare una condizione pericolosa che potrebbe causare lesioni gravi o mortali.

Para obtener el manual de instrucciones del Configurable Safety Controller (GFK-3184)

Visite <https://www.emerson.com/industrial-automation-controls/support> para descargar el manual.

WARNING

Es responsabilidad del personal calificado:

- Leer con atención, entender y seguir la información en el manual de instrucciones de la Configurable Safety Controller (GFK-3184).
- Realizar una evaluación de riesgos que incluya la aplicación de protección de la máquina específica
- Determinar qué medidas de reducción de riesgos son apropiadas según los resultados de la evaluación de riesgos
- Instale, configure y luego verifique correctamente que las medidas de reducción de riesgos funcionan según lo previsto
- Vuelva a verificar periódicamente, según sea necesario, que las medidas de reducción de riesgos funcionan según lo previsto

El incumplimiento de cualquiera de estas responsabilidades puede crear potencialmente una condición peligrosa que podría provocar lesiones graves o la muerte.

General Contact Information

Home link: <http://www.emerson.com/industrial-automation-controls>
Knowledge Base: <https://www.emerson.com/industrial-automation-controls/support>

Technical Support

Americas

Phone: 1-888-565-4155
1-434-214-8532 (If toll free option is unavailable)

Customer Care (Quotes/Orders>Returns): customercare.mas@emerson.com
Technical Support: support.mas@emerson.com

Europe

Phone: +800-4444-8001
+420-225-379-328 (If toll free option is unavailable)

Customer Care (Quotes/Orders>Returns): customercare.emea.mas@emerson.com
Technical Support: support.mas.emea@emerson.com

Asia

Phone: +86-400-842-8599
+65-6955-9413 (All other Countries)

Customer Care (Quotes/Orders>Returns): customercare.cn.mas@emerson.com
Technical Support: support.mas.apac@emerson.com

Any escalation request should be sent to: mas.sfdcescalation@emerson.com

Note: If the product is purchased through an Authorized Channel Partner, please contact the seller directly for any support.

Emerson reserves the right to modify or improve the designs or specifications of the products mentioned in this manual at any time without notice. Emerson does not assume responsibility for the selection, use or maintenance of any product. Responsibility for proper selection, use and maintenance of any Emerson product remains solely with the purchaser.

© 2021 Emerson. All rights reserved.

Emerson Terms and Conditions of Sale are available upon request. The Emerson logo is a trademark and service mark of Emerson Electric Co. All other marks are the property of their respective owners.